

MPOS - PH

MODELLO MODEL MODÈLE MODELL	ROTORE ROTATORS ROTATORS DREHGERÄTE	CAPACITA' CAPACITY CAPACITÉ INHALT	PRESSIONE PRESSURE PRESSION DRUCK	DENTI / PESO TEETH / WEIGHT DENTS / POIDS ZÄHNE / GEWICHT			DIMENSIONI (mm) SIZES (mm) DIMENSIONS (mm) ABMESSUNGEN (mm)						MACCHINA MACHINE MACHINE MASCHINE
				TON	LT	MAX-BAR	N°/KG			A	B	C	
MPOS 350 PH	-	350	330	4/650	5/710	6/770	1320	1740	1930	1120	870	130	12-16
MPOS 350 PH - OR 2 S	10	350	330	4/720	5/780	6/880	1320	1740	1930	1120	870	270	12-16
MPOS 450 PH	-	450	330	4/670	5/760	6/830	1340	1840	2050	1170	890	130	14-20
MPOS 450 PH - OR 2 S	10	450	330	4/780	5/870	6/940	1340	1840	2050	1170	890	270	14-20
MPOS 550 PH	-	550	330	4/740	5/830	6/920	1360	1940	2170	1220	910	130	19-23
MPOS 550 PH - OR 2 S	10	550	330	4/850	5/950	6/1040	1360	1940	2170	1220	910	270	19-23
MPOS 550 PH - OR 1 S	15	550	330	4/970	5/1070	6/1160	1360	1940	2170	1220	910	310	23-28

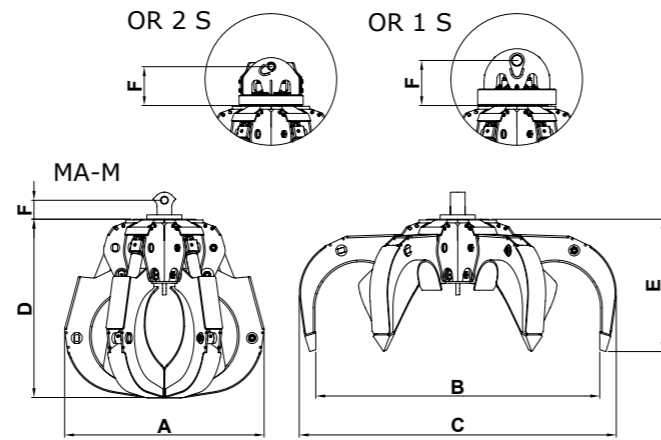

MODELLO MODEL MODÈLE MODELL	ROTORE ROTATORS ROTATORS DREHGERÄTE	CAPACITA' CAPACITY CAPACITÉ INHALT	PRESSIONE PRESSURE PRESSION DRUCK	DENTI / PESO TEETH / WEIGHT DENTS / POIDS ZÄHNE / GEWICHT			DIMENSIONI (mm) SIZES (mm) DIMENSIONS (mm) ABMESSUNGEN (mm)						MACCHINA MACHINE MACHINE MASCHINE
				TON	LT	MAX-BAR	N°/KG			A	B	C	
MPOS 600 FH	-	600	330	-	5/1070	6/1220	1600	1990	2230	1230	950	210	22-40
MPOS 600 FH - OR 1 S	15	600	330	-	5/1230	6/1380	1600	1990	2230	1230	950	310	22-40
MPOS 700 FH	-	700	330	-	5/1170	6/1320	1600	2130	2380	1300	970	210	25-45
MPOS 700 FH - OR 1 S	15	700	330	-	5/1330	6/1480	1600	2130	2380	1300	970	310	25-45

MPOS - FHI

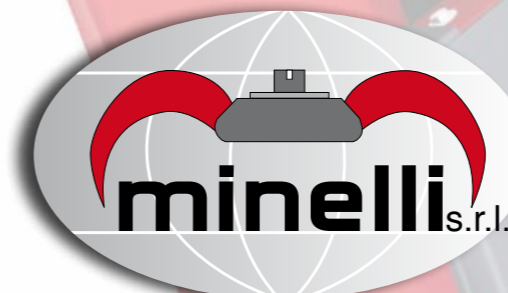
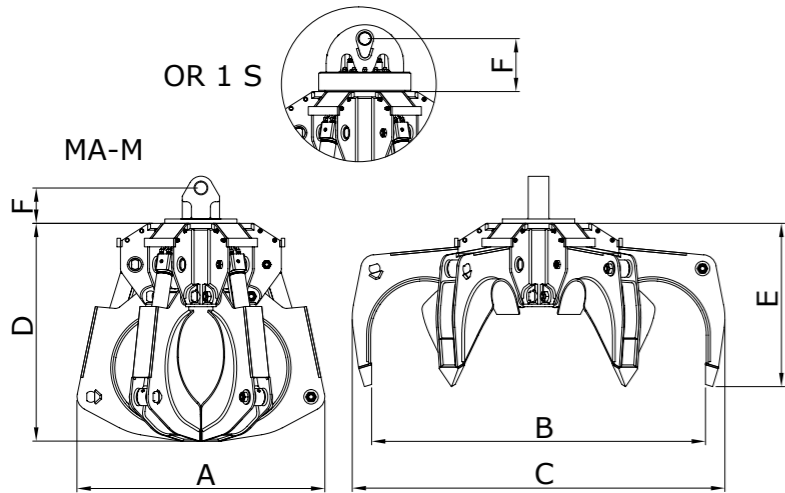

Hydraulic Equipment Industries

POLIPI PER LA MOVIMENTAZIONE DI ROTTAME, RIFIUTI E MATERIALE VARIO



Per maggiori dettagli tecnici consultate il nostro sito www.minellisrl.it oppure inviateci richiesta di maggiori informazioni al nostro indirizzo e-mail info@minellisrl.it

Pour obtenir de plus amples détails technique vous pouvez consulter notre site www.minellisrl.it ou en faisant parvenir vos demandes à l'adresse E-mail info@minellisrl.it.

For further technical details please visit our website www.minellisrl.it or contact us at info@minellisrl.it

Weitere technische Details erfahren Sie auf unserer Webseite www.minellisrl.it; gern stehen wir Ihnen auch unter der E-mail Anschrift info@minellisrl.it für jede weitergehende Information zur Verfügung.

- Dati e pesi sono indicativi: la ditta si riserva il diritto di apportare senza preavviso migliorie e modifiche necessarie per il buon funzionamento.
- Data and weight are indicative: the company reserve the right to make any improvements and changes required for good operation, without giving advance notice.
- Les données et les poids sont à titre indicatif: l'entreprise se réserve d'apporter sans préavis, les améliorations et les modifications nécessaires au bon fonctionnement.
- Daten und Gewichte sind nur zur Orientierung gedacht: Die Firma behält sich das Recht vor, ohne Vorankündigung Verbesserungen und Änderungen vorzunehmen die zur einwandfreien Funktionsweise notwendig sein sollten.

Orange peel buckets for moving scrap, waste and loose materials.

Grappins pour la manutention de débris, déchets et de matériaux en vrac.

Mehrschalengreifer zum bewegen von schrott und losem Materialien.



Minelli s.r.l.
via Bonfadina, 81/83 | Cazzago S.M. (Bs) Italy | tel. 030 77 51 509 r.a. | fax 030 77 51 510 | info@minellisrl.it | www.minellisrl.it



Hydraulic Equipment Industries

Minelli s.r.l. è un'azienda specializzata nella produzione di attrezzature oleodinamiche per la movimentazione di materiali sfusi, con particolare riferimento ai settori rottame, ecologia, riciclaggio e demolizione.

Decenni di esperienza nel settore, attenzione alle esigenze dei clienti, soluzioni tecniche sviluppate in collaborazione con i principali costruttori di gru e macchine operatrici uniti all'utilizzo dei migliori materiali, sono le basi da cui nascono i prodotti Minelli.

Una vasta gamma di attrezzature particolarmente studiata per limitare il peso e l'ingombro dell'attrezzo senza trascurare la capacità di raccolta, la resistenza ai lavori più gravosi e mantenendo invariate tutte le caratteristiche qualitative dei prodotti MINELLI.

Le attrezzature MINELLI sono costruite con acciaio di qualità certificato **HARDOX** e **WELDOX**, gli steli dei cilindri sono cromati e temperati, i perni sono in acciaio legato e temperato. Le punte delle pale sono in acciaio speciale antiusura.

Minelli s.r.l. is a company specialized in the production of oil hydraulic equipment for the handling of loose materials, with particular reference to the scrap, ecology, recycling and demolition sectors.

The foundations of Minelli's products are its decades of experience, attention to customer needs, provision of customized technical solutions developed in collaboration with the main crane manufacturers and equipment operators together with the use of the best materials.

The company produces a broad range of equipment particularly developed to limit the weight and space required to operate without neglecting the lifting and transport capacity, the resistance to heavy duty tasks and maintaining the traditional quality standards of its products unchanged.

MINELLI's equipments are constructed with **HARDOX** and **WELDOX** certified steel, the rods are chromium-plated and hardened and the hinges are made of hardened steel alloys. The tips of the blades are made of special wear-proof steel.

Minelli s.r.l. est une entreprise spécialisée dans la production d'outillages oleodynamiques pour le déplacement de matériaux et matières en vrac, employés tout particulièrement dans les secteurs de la ferraille, de l'écologie, du recyclage et de la démolition.

Une attention constante aux exigences des nos clients, des solutions techniques élaborées en partenariat avec les principaux constructeurs de pelles mécaniques et de grues et l'emploi exclusif de matériaux de haute qualité, à quoi s'ajoute des dizaines d'années d'expérience dans les secteurs cités, nous ont permis d'obtenir une gamme d'outillage répondant au mieux aux nécessités de nos clients.

Tous les outillages, composant notre gamme qui couvre la quasi-totalité des besoin de déplacement, ont été étudiés pour en limiter le poids et l'encombrement tout en conservant une grande capacité et une grande résistance dans les travaux les plus « lourds ».

Les outillages Minelli sont construits en acier de haute qualité certifié **HARDOX** et **WELDOX**. Les tiges des cylindres sont chromés et trempés, les pivots sont en acier lié et trempé. Les pointes des pales sont en acier spécial anti-usure.

Minelli s.r.l. ist ein Fachunternehmen in der Herstellung von öldynamischen Ausrüstungen zum Handling und Transport von Schüttgut und losem Material, insbesondere in den Bereichen Verschrottung, Entsorgung, Recycling, Abbau- und Abbruchmaßnahmen.

Eine Jahrzehnte lange Erfahrung in diesen Sektoren, eine kundenorientierte Projektgestaltung- und Umsetzung, technische Lösungen, die in enger Zusammenarbeit mit führenden Herstellern von Hebekränen und ähnlichen Maschinen entwickelt werden, der Einsatz erstklassiger Werkstoffe: dies sind die wesentlichen Voraussetzungen und Merkmale, die Minelli Produkte kennzeichnen.

Das Ergebnis ist ein umfangreiches Sortiment von Ausrüstungen, die in Hinsicht auf Umfang und Gewicht so kompakt und funktionsgerecht wie möglich gestaltet sind, bei gleichzeitiger Gewährleistung von hoch widerstandsfähigen Materialien bester Qualität, die den fachgerechten Einsatz von Minelli Produkten auch unter schwersten Belastungen ermöglichen.

MINELLI Ausrüstungen werden aus hochwertigem Stahl mit **HARDOX** und **WELDOX** Zertifizierung gefertigt, die Schäfte der Zylinder sind aus gehärtetem und verchromtem Stahl, die Gelenkzapfen aus legiertem und gehärteten Stahl, die spitzen der Schalen sind aus verschleißfestem Spezialstahl.



MPOS - PZL

MODELLO MODEL MODÈLE MODELL	ROTORE ROTATORS ROTATORS DREHGERÄTE	CAPACITA' CAPACITY CAPACITÉ INHALT	PESO WEIGHT POIDS GEWICHT	DENTI TEETH DENTS ZÄHNE	PRESSIONE PRESSURE PRESSION DRUCK	MACCHINA MACHINE MACHINE MASCHINE
	TON	LT	KG	N°	MAX-BAR	MAX-TON.
MPOS 300/6 P ZL	-	300	420	6	300	8-12
MPOS 300/6 P ZL RI	6	300	465	6	300	8-12

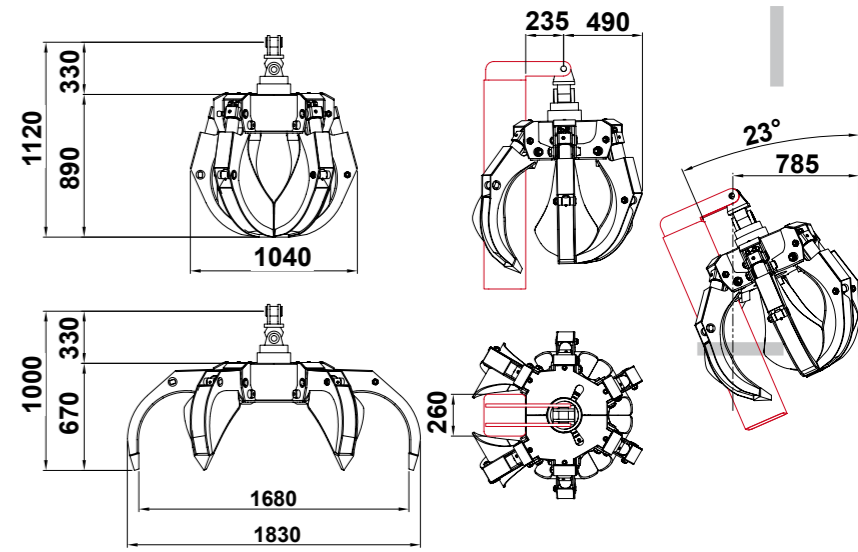

MODELLO MODEL MODÈLE MODELL	ROTORE ROTATORS ROTATORS DREHGERÄTE	CAPACITA' CAPACITY CAPACITÉ INHALT	PRESSIONE PRESSURE PRESSION DRUCK	DENTI / PESO TEETH / WEIGHT DENTS / POIDS ZÄHNE / GEWICHT	DIMENSIONI (mm) SIZES (mm) DIMENSIONS (mm) ABMESSUNGEN (mm)							MACCHINA MACHINE MACHINE MASCHINE	
	TON	LT	MAX-BAR	N°/KG	A	B	C	D	E	F	MAX-TON.		
MPOS 140 P	-	140	300	4/240	-	-	920	1260	1420	680	620	30	5-8
MPOS 140 P RI	4	140	300	4/275	-	-	920	1260	1420	680	620	110	5-8
MPOS 180 P	-	180	300	-	5/300	-	970	1400	1570	760	640	30	6-10
MPOS 180 P RI	4	180	300	-	5/335	-	970	1400	1570	760	640	110	6-10
MPOS 180 P RI	6	180	300	-	5/345	-	970	1400	1570	760	640	130	6-10
MPOS 240 P	-	240	300	-	-	6/370	980	1450	1600	790	650	30	8-12
MPOS 240 P RI	6	240	300	-	-	6/415	980	1450	1600	790	650	130	8-12
MPOS 250 P	-	250	300	4/300	5/350	6/390	1010	1560	1720	840	670	30	8-12
MPOS 250 P RI	6	250	300	4/345	5/395	6/435	1010	1560	1720	840	670	130	8-12
MPOS 300 P	-	300	300	4/340	5/380	6/420	1050	1680	1840	910	690	30	8-12
MPOS 300 P RI	6	300	300	4/385	5/425	6/465	1050	1680	1840	910	690	130	8-12
MPOS 350 P	-	350	300	-	-	6/450	1120	1740	1920	940	700	30	8-12
MPOS 350 P RI	6	350	300	-	-	6/495	1120	1740	1920	940	700	130	8-12
MPOS 400 P	-	400	300	-	-	6/450	1080	1890	2040	1010	720	30	8-12
MPOS 400 P RI	6	400	300	-	-	6/495	1080	1890	2040	1010	720	130	8-12

MPOS - P

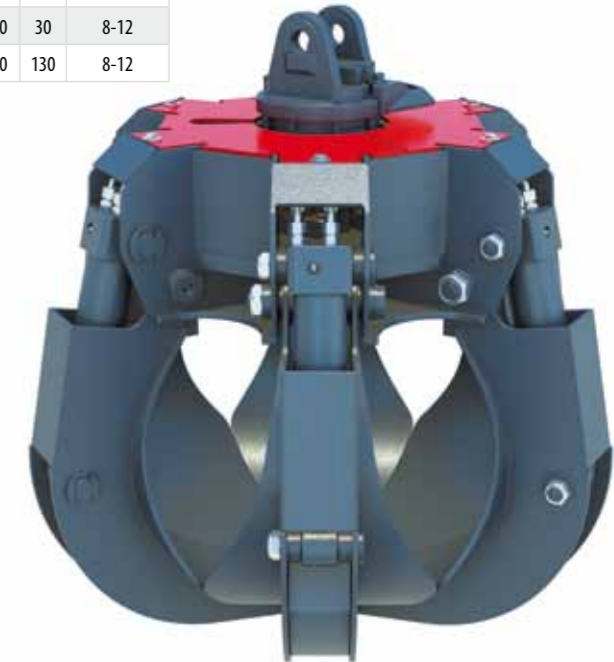
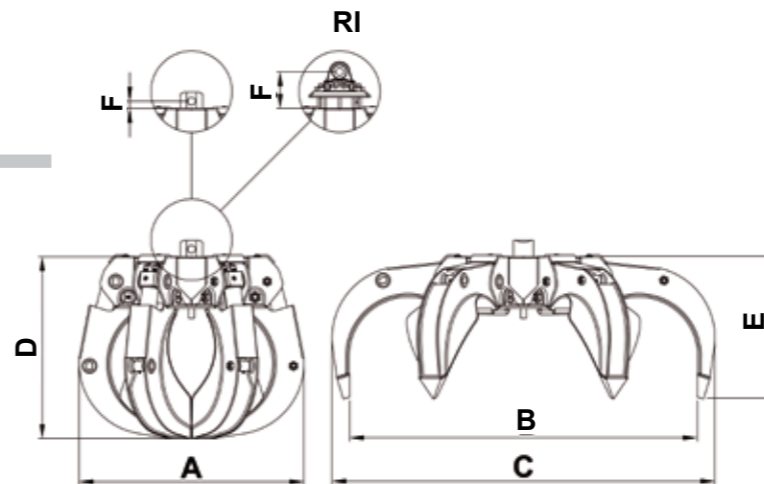

MPOS - PZ

MODELLO MODEL MODÈLE MODELL	ROTORE ROTATORS ROTATORS DREHGERÄTE	CAPACITA' CAPACITY CAPACITÉ INHALT	PESO WEIGHT POIDS GEWICHT	DENTI TEETH DENTS ZÄHNE	PRESSIONE PRESSURE PRESSION DRUCK	DIMENSIONI (mm) SIZES (mm) DIMENSIONS (mm) ABMESSUNGEN (mm)										MACCHINA MACHINE MACHINE MASCHINE
	TON	LT	KG	N°	MAX-BAR	A	B	C	D	E	F	G	H	I	MAX-TON.	
MPOS 250/6 PZ	-	250	390	6	300	1010	1560	1720	820	650	330	230	640	890	7-12	
MPOS 250/6 PZ RI	6	250	435	6	300	1010	1560	1720	820	650	330	230	640	890	7-12	
MPOS 300/6 PZ	-	300	420	6	300	1040	1680	1830	890	670	330	230	650	935	8-12	
MPOS 300/6 PZ RI	6	300	465	6	300	1040	1680	1830	890	670	330	230	650	935	8-12	

